

# **ECLIPSE**

## **CASED CANTILEVER SPRING ENERGIZED SEAL**



**EVSC SERIES**

**FULL SERVICE SEAL & BEARING ENGINEERING,  
MANUFACTURING AND DISTRIBUTION.**

**Address**

2540 S Main St., Erie, CO 80516  
p: 303-460-1540 / f: 303-635-3005

**Contact**

[sales@eclipseseal.com](mailto:sales@eclipseseal.com)  
[www.eclipseseal.com](http://www.eclipseseal.com)



# TABLE OF CONTENTS

Full service seal & bearing engineering, manufacturing and distribution.

03 | Spring Seal Rod introduction

---

04 | Ordering overview

---

05 | Standard materials

---

06 | Standard part numbers

---

16 | Hardware details



## ECLIPSE EVSC - CASED CANTILEVER SPRING ENERGIZED SEAL

Cased Spring Seals are the best option for extreme rotary service. In these designs, a metal case is constructed around the outside of a spring seal, which in turn gets press-fit into the hardware bore. A metal-to-metal press-fit ensures a tight seal as well as a highly effective anti-rotation mechanism. Because these seals are installed into open bores, they lend themselves to rotary applications such as gearboxes and power transmission systems. They can also be utilized as rod end scrapers, where exclusion of aggressive media is desired.

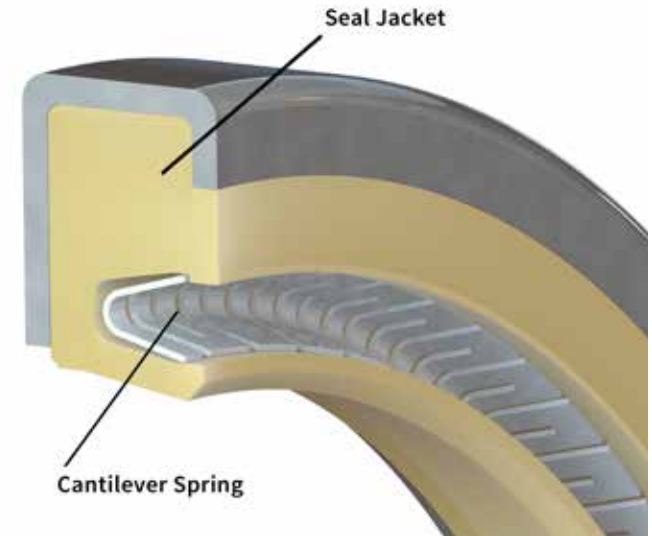

### TYPICAL RANGE OF APPLICATION

Pressure	Temperature
Vacuum to 3,000 psi [0 to 200 bar]	-320°F to 450°F [-195°C to 230°C]

Ratings will vary based on materials and operating conditions

*Values and ratings in this catalog are based on industry standard applications operating under ideal conditions. The customer should assume responsibility for validation testing of performance and suitability of Eclipse Engineering products. Eclipse Engineering accepts no liability for the accuracy and applicability of provided information.*

STANDARD ORDERING EXAMPLE:

**EVSC-R-548-LW-ET006-M-S-S**

- EVSC** = Seal Series
- R** = Rod
- 548** = Dash Number
- LW** = Lip Style
- ET006** = Seal Material Code
- M** = Spring Load  
L - Light  
M - Medium  
H - Heavy
- S** = Spring Material  
S - Stainless Steel  
E - Elgiloy®  
H - Hastelloy®
- S** = Case Material  
S - Stainless Steel  
A - Aluminum

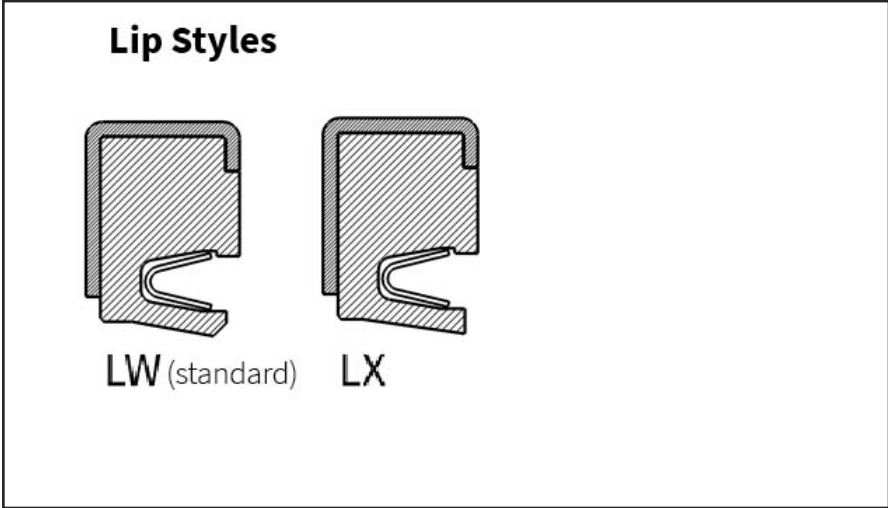

NON-STANDARD ORDERING EXAMPLE:

**EVSC-R-C-02953-LW-ET006-M-S-S**

- C** = Nominal Cross-Section  
A = 1/4 in. (400 Series)  
B = 5/16 in. (500 Series)  
C = 3/8 in. (600 Series)  
D = 7/16 in. (700 Series)  
E = 1/2 in. (800 Series)
- 02953** = Rod Diameter in 1000ths  
Example: 02953 = Ø2.953  
[75MM] Rod Diameter



## EVSC STANDARD SEAL MATERIALS

ECLIPSE MATERIAL CODE	DESCRIPTION	COLOR	APPLICATIONS
ET000	Virgin PTFE	White	Light Duty / Static / Cryogenics
ET006	Carbon filled PTFE	Black	General Purpose
EU000	Virgin UHMWPE	Translucent White	Viscous Media / Water
ET014	Polyimide filled PTFE	Orange/Brown	High Sealability / Soft Hardware

See [Eclipse Material Guide](#) for complete list of available materials.

## EVSC STANDARD SPRING MATERIALS

ECLIPSE MATERIAL CODE	SPRING MATERIAL	APPLICATION
S	300 Series Stainless Steel	General purpose, standard spring material
E	Elgiloy®	Improved performance and corrosion resistance; NACE approved
H	Hastelloy® C276	Maximum chemical/corrosion resistance

## 400 SERIES STANDARD DASH NUMBERS

GLAND TOLERANCES		
SEAL ID	$\varnothing A$	$\varnothing B$
0.125 to 0.374	+0.000 -0.001	$\pm 0.001$
0.375 to 2.999	+0.000 -0.002	$\pm 0.001$
3.000 to 5.999	+0.000 -0.003	$\pm 0.0015$
6.000 and up	+0.000 -0.004	$\pm 0.002$

400 SERIES MAXIMUM EXTRUSION GAP (E), AT 70° F		
300 psi	1500 psi	3000 psi
0.010	0.006	0.004

Consult Eclipse Engineering for all custom or unlisted sizes.

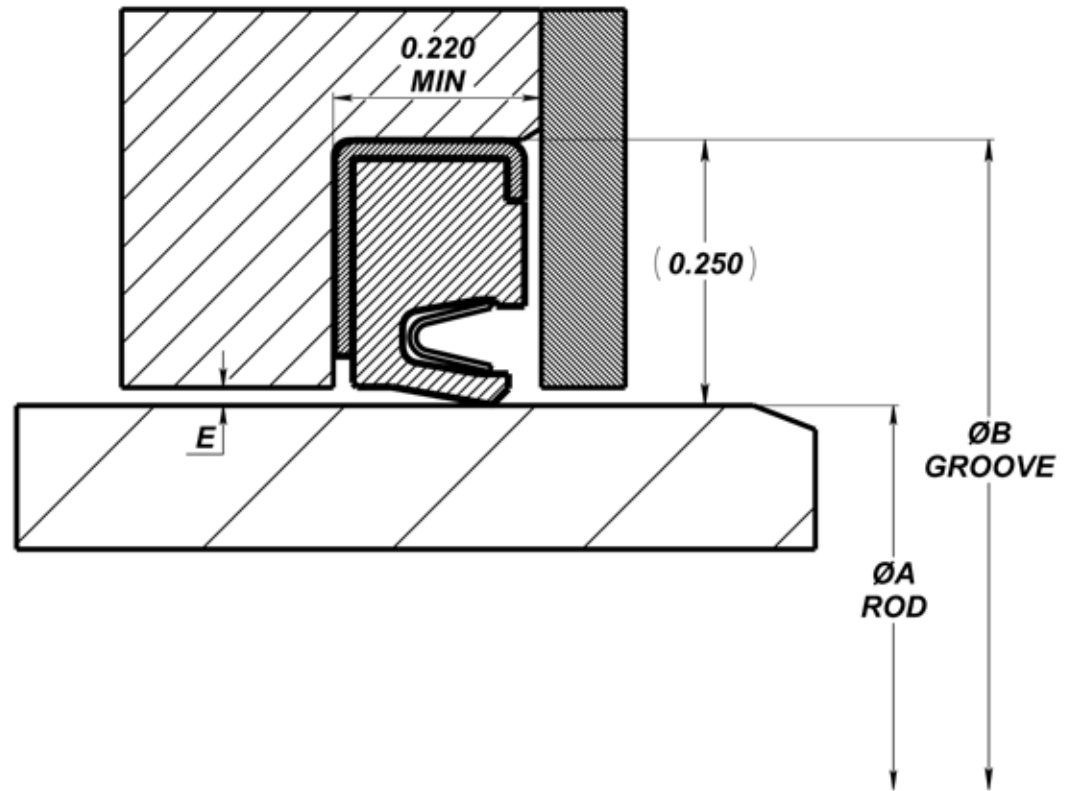

**400 SERIES STANDARD DASH NUMBERS:**

DASH #	A	B
404	0.250	0.750
405	0.313	0.813
406	0.375	0.875
407	0.438	0.938
408	0.500	1.000
409	0.563	1.063
410	0.625	1.125
411	0.688	1.188
412	0.750	1.250
413	0.813	1.313
414	0.875	1.375
415	0.938	1.438
416	1.000	1.500
417	1.063	1.563
418	1.125	1.625
419	1.188	1.688

DASH #	A	B
420	1.250	1.750
421	1.313	1.813
422	1.375	1.875
423	1.438	1.938
424	1.500	2.000
425	1.563	2.063
426	1.625	2.125
427	1.688	2.188
428	1.750	2.250
429	1.813	2.313
430	1.875	2.375
431	1.938	2.438
432	2.000	2.500
433	2.063	2.563
434	2.125	2.625
435	2.188	2.688

DASH #	A	B
436	2.250	2.750
437	2.313	2.813
438	2.375	2.875
439	2.438	2.938
440	2.500	3.000
441	2.563	3.063
442	2.625	3.125
443	2.688	3.188
444	2.750	3.250
445	2.813	3.313
446	2.875	3.375
447	2.938	3.438
448	3.000	3.500
449	3.063	3.563
450	3.125	3.625
451	3.188	3.688

DASH #	A	B
452	3.250	3.750
453	3.313	3.813
454	3.375	3.875
455	3.438	3.938
456	3.500	4.000
457	3.563	4.063
458	3.625	4.125
459	3.688	4.188
460	3.750	4.250
461	3.813	4.313
462	3.875	4.375
463	3.938	4.438
464	4.000	4.500
465	4.063	4.563
466	4.125	4.625

Consult Eclipse Engineering for all custom or unlisted sizes.

## 500 SERIES STANDARD DASH NUMBERS

GLAND TOLERANCES		
SEAL ID	ØA	ØB
0.125 to 0.374	+0.000 -0.001	± 0.001
0.375 to 2.999	+0.000 -0.002	± 0.001
3.000 to 5.999	+0.000 -0.003	± 0.0015
6.000 and up	+0.000 -0.004	± 0.002

500 SERIES MAXIMUM EXTRUSION GAP (E), AT 70° F		
300 psi	1500 psi	3000 psi
0.014	0.008	0.006

Consult Eclipse Engineering for all custom or unlisted sizes.

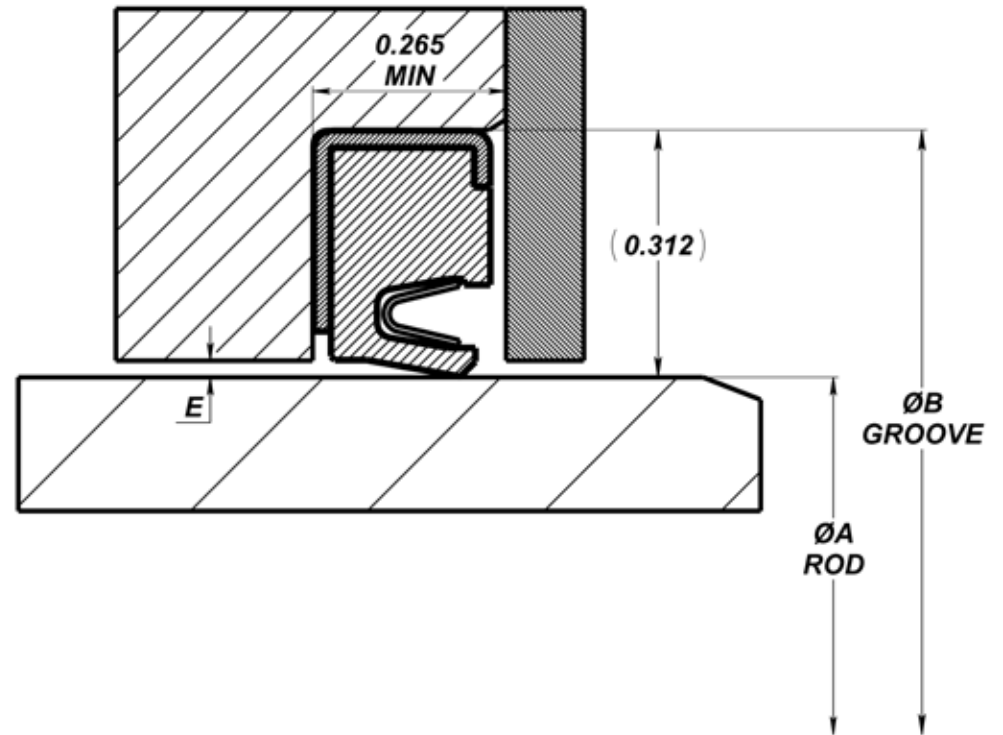





**500 SERIES STANDARD DASH NUMBERS:**

DASH #	A	B
508	0.500	1.125
510	0.625	1.250
512	0.750	1.375
514	0.875	1.500
516	1.000	1.625
518	1.125	1.750
520	1.250	1.875
522	1.375	2.000

DASH #	A	B
524	1.500	2.125
526	1.625	2.250
528	1.750	2.375
530	1.875	2.500
532	2.000	2.625
534	2.125	2.750
536	2.250	2.875
538	2.375	3.000

DASH #	A	B
540	2.500	3.125
542	2.625	3.250
544	2.750	3.375
546	2.875	3.500
548	3.000	3.625
550	3.125	3.750
552	3.250	3.875
554	3.375	4.000

DASH #	A	B
556	3.500	4.125
558	3.625	4.250
560	3.750	4.375
562	3.875	4.500
564	4.000	4.625

Consult Eclipse Engineering for all custom or unlisted sizes.

## 600 SERIES STANDARD DASH NUMBERS

GLAND TOLERANCES		
SEAL ID	ØA	ØB
0.125 to 0.374	+0.000 -0.001	± 0.001
0.375 to 2.999	+0.000 -0.002	± 0.001
3.000 to 5.999	+0.000 -0.003	± 0.0015
6.000 and up	+0.000 -0.004	± 0.002

600 SERIES MAXIMUM EXTRUSION GAP (E), AT 70° F		
300 psi	1500 psi	3000 psi
0.014	0.008	0.006

Consult Eclipse Engineering for all custom or unlisted sizes.

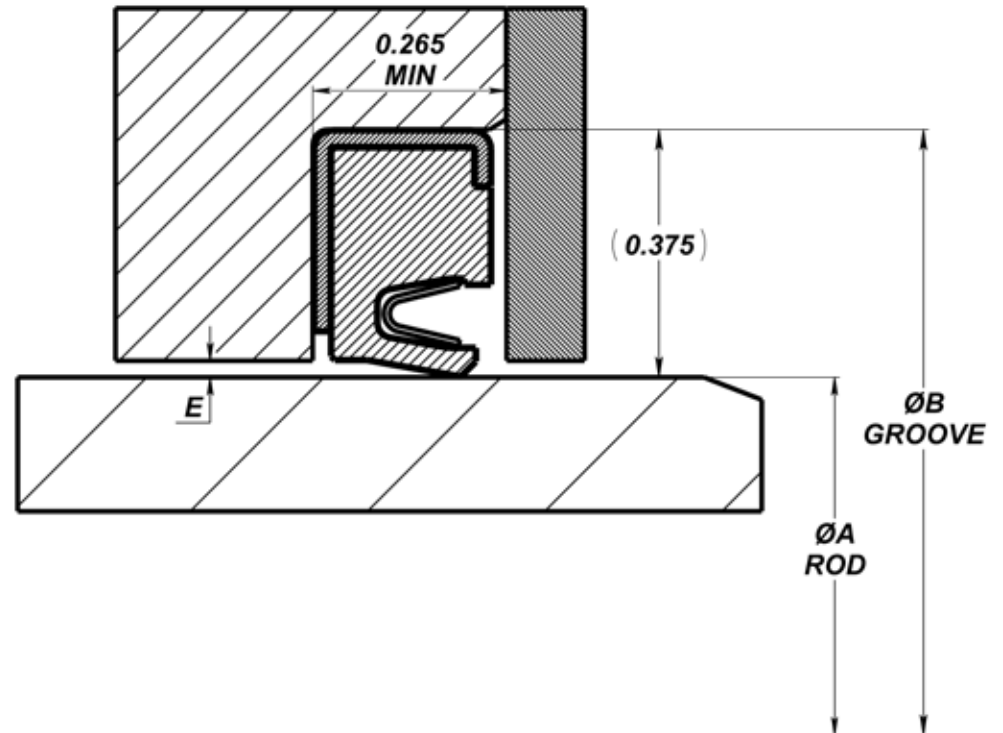



**600 SERIES STANDARD DASH NUMBERS:**

DASH #	A	B
608	0.500	1.250
610	0.625	1.375
612	0.750	1.500
614	0.875	1.625
616	1.000	1.750
618	1.125	1.875
620	1.250	2.000
622	1.375	2.125

DASH #	A	B
624	1.500	2.250
626	1.625	2.375
628	1.750	2.500
630	1.875	2.625
632	2.000	2.750
634	2.125	2.875
636	2.250	3.000
638	2.375	3.125

DASH #	A	B
640	2.500	3.250
642	2.625	3.375
644	2.750	3.500
646	2.875	3.625
648	3.000	3.750
650	3.125	3.875
652	3.250	4.000
654	3.375	4.125

DASH #	A	B
656	3.500	4.250
658	3.625	4.375
660	3.750	4.500
662	3.875	4.625
664	4.000	4.750

Consult Eclipse Engineering for all custom or unlisted sizes.

## 700 SERIES STANDARD DASH NUMBERS

GLAND TOLERANCES		
SEAL ID	ØA	ØB
0.125 to 0.374	+0.000 -0.001	± 0.001
0.375 to 2.999	+0.000 -0.002	± 0.001
3.000 to 5.999	+0.000 -0.003	± 0.0015
6.000 and up	+0.000 -0.004	± 0.002

700 SERIES MAXIMUM EXTRUSION GAP (E), AT 70° F		
300 psi	1500 psi	3000 psi
0.020	0.010	0.008

Consult Eclipse Engineering for all custom or unlisted sizes.

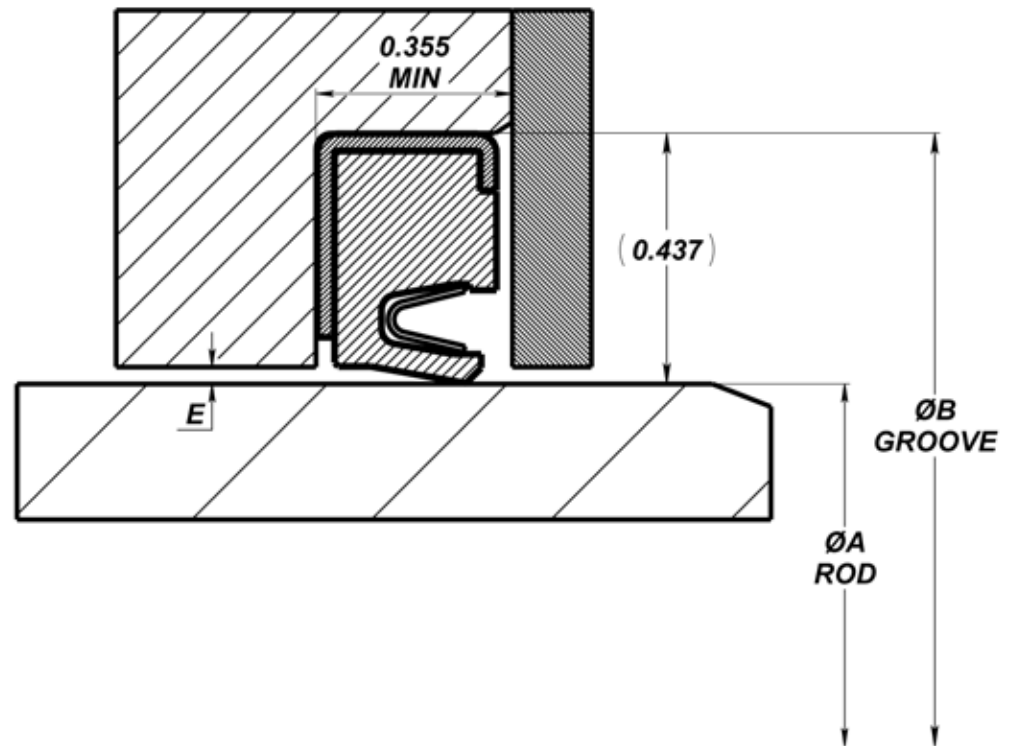



**700 SERIES STANDARD DASH NUMBERS:**

DASH #	A	B
712	0.750	1.625
714	0.875	1.750
716	1.000	1.875
718	1.125	2.000
720	1.250	2.125
722	1.375	2.250
724	1.500	2.375

DASH #	A	B
726	1.625	2.500
728	1.750	2.625
730	1.875	2.750
732	2.000	2.875
734	2.125	3.000
736	2.250	3.125
738	2.375	3.250

DASH #	A	B
740	2.500	3.375
742	2.625	3.500
744	2.750	3.625
746	2.875	3.750
748	3.000	3.875
750	3.125	4.000
752	3.250	4.125

DASH #	A	B
754	3.375	4.250
756	3.500	4.375
758	3.625	4.500
760	3.750	4.625
762	3.875	4.750
764	4.000	4.875

Consult Eclipse Engineering for all custom or unlisted sizes.

## 800 SERIES STANDARD DASH NUMBERS

GLAND TOLERANCES		
SEAL ID	ØA	ØB
0.125 to 0.374	+0.000 -0.001	± 0.001
0.375 to 2.999	+0.000 -0.002	± 0.001
3.000 to 5.999	+0.000 -0.003	± 0.0015
6.000 and up	+0.000 -0.004	± 0.002

800 SERIES MAXIMUM EXTRUSION GAP (E), AT 70° F		
300 psi	1500 psi	3000 psi
0.024	0.012	0.010

Consult Eclipse Engineering for all custom or unlisted sizes.

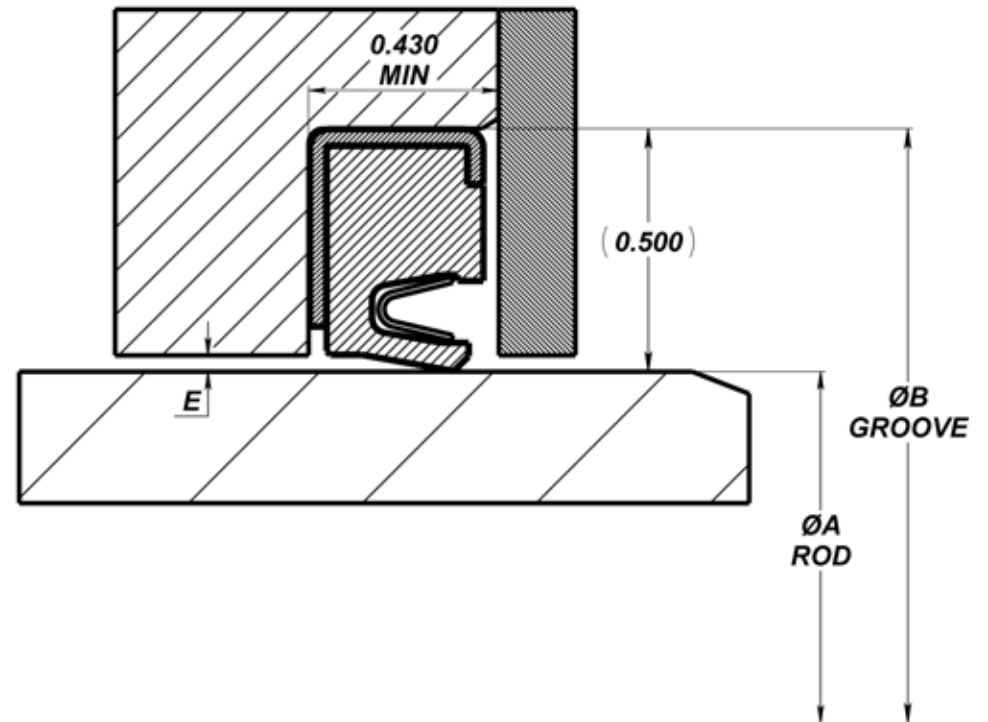



**800 SERIES STANDARD DASH NUMBERS:**

DASH #	A	B
820	1.250	2.250
822	1.375	2.375
824	1.500	2.500
826	1.625	2.625
828	1.750	2.750
830	1.875	2.875

DASH #	A	B
832	2.000	3.000
834	2.125	3.125
836	2.250	3.250
838	2.375	3.375
840	2.500	3.500
842	2.625	3.625

DASH #	A	B
844	2.750	3.750
846	2.875	3.875
848	3.000	4.000
850	3.125	4.125
852	3.250	4.250
854	3.375	4.375

DASH #	A	B
856	3.500	4.500
858	3.625	4.625
860	3.750	4.750
862	3.875	4.875
864	4.000	5.000

Consult Eclipse Engineering for all custom or unlisted sizes.

## HARDWARE DETAILS - SPLIT GLAND

SERIES	R RADIUS MAX	C1 CHAMFER MIN	C2 CHAMFER MIN
000	0.010	0.010	0.031
100	0.015	0.015	0.050
200	0.015	0.015	0.062
300	0.015	0.020	0.093
400	0.020	0.020	0.125

Consult Eclipse Engineering for application/material specific design requirements or for use in solid or non-standard glands.

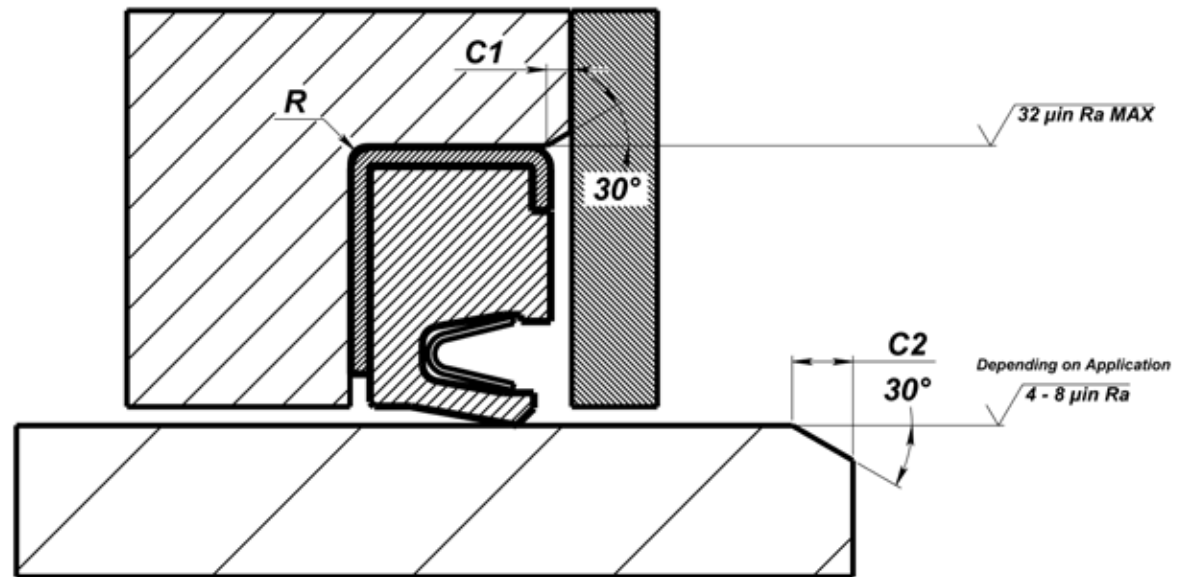



**We started Eclipse with the premise that if we could solve enough of our customers problems they would continue to come back to us for solutions regardless of the type of products we offered.**



Eclipse has evolved to produce standard product offerings for a wide range of industries including Hydraulics, Pneumatics, Energy Production, Aerospace as well as Pharmaceutical and Food Handling. Instituting ISO9001/AS9100 quality system in 2015 allowed Eclipse to become a top tier supplier.

Today, Eclipse can support our smaller customers that require only a few seals a year to those needing in the 100's of thousands. We continue to retain a quality product and are able to deliver consistently on time. Our customers continue to bring us challenging projects that allow our team to do what we do best, problem solving.



 **eclipse** | engineering inc.



---

**Address**

2540 S Main St., Erie, CO 80516  
p: 303-460-1540 / f: 303-635-3005

**Contact**

[sales@eclipseseal.com](mailto:sales@eclipseseal.com)  
[www.eclipseseal.com](http://www.eclipseseal.com)

**Eclipse Engineering**

Full service seal & bearing engineering,  
manufacturing and distribution.